



---

# Pyroelectric Infrared Radial Sensor

TYPE: Am612  
NANYANG SENBA OPTICAL AND ELECTRONIC CO., LTD.



## Digital Smart Pyroelectric Detector AM612

AM612 is a newest smart digital motion detector. This Smart digital detector offers a complete motion detector solution, with all electronic circuitry built into the detector housing. Only a power supply and power-switching components need to be added to make the entire motion switch, a timer is included. The series has versions which can include ambient light level and sensitivity adjustments.

### **n Features and Benefits**

- n Digital signal processing (DSP)
- n Power adjustable, save more energy
- n Two-way differential high impedance sensor input
- n Built-in filter, screen the interference by other frequency
- n Excellent power supply rejection, Insensitive to RF interference
- n Schmidt REL output
- n Low voltage, low power consumption, instantaneous settling after power up

### **n Applications**

- n Toys
- n Digital photo frame
- n TV, Refrigerator, Air-conditioner
- n USB Alarms
- n PIR motion detection
- n Intruder detection
- n Occupancy detection
- n Motion sensor lights
- n Computer monitor
- n Security system
- n Automatic control
- n Corridor
- n Stairs Lights etc.

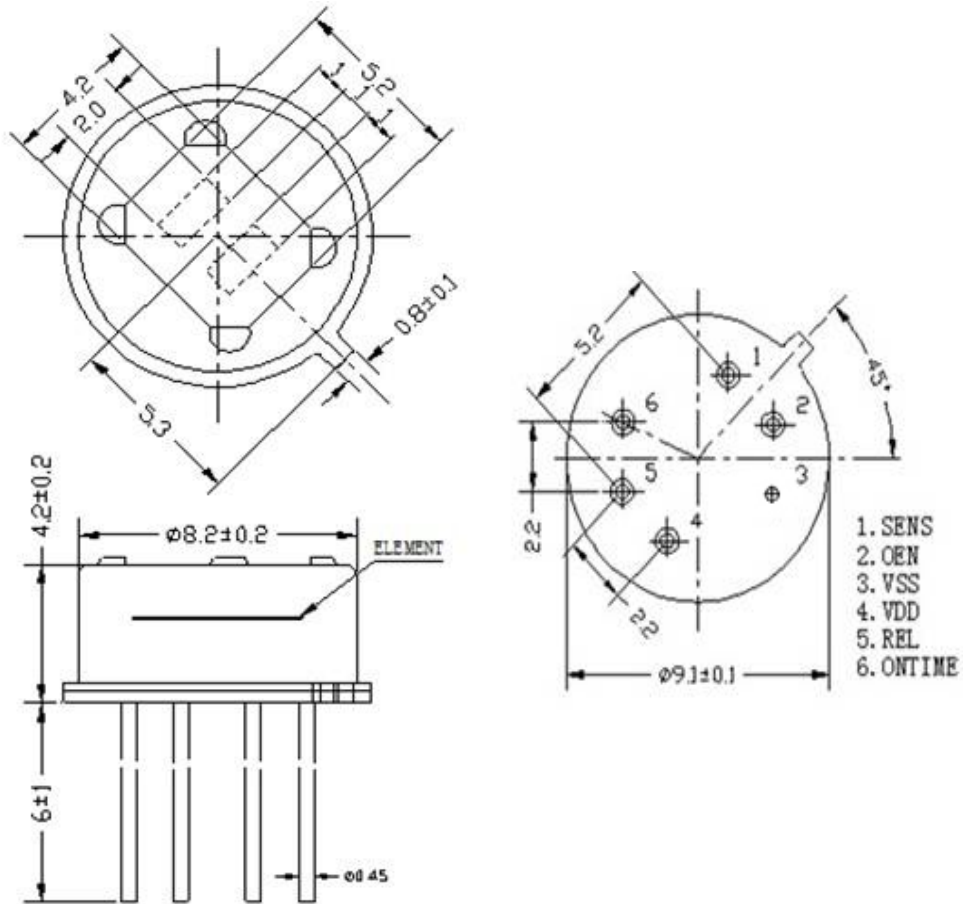
**n Dimension**

PIR Dimension (A)

Fresnel Lens Dimension (B)

Notes: Dimension A can be used with Dimension B.



## n Technical Data

### 1. Maximum Ratings

Characteristics	Symbol	Min. Value	Max. Value	Unit	Remarks
Supply Voltage	V <sub>DD</sub>	-0.3	3.6	V	
Working Temperature	T <sub>ST</sub>	-20	85	°C	
Max.current	I <sub>nto</sub>	-100	100	mA	
Storage Temperature	T <sub>ST</sub>	-40	125	°C	

### 2. Working Conditions (T=25°C, V<sub>dd</sub>=3V, Except other requirements)

Characteristics	Symbol	Min.	Type	Max.	Unit	Remarks
Supply Voltage	V <sub>DD</sub>	2.7	3	3.3	V	I <sub>R</sub> =0.5mA
Working Current	I <sub>DD</sub>	12	15	20	μA	
Sensitivity threshold value	V <sub>SENS</sub>	120		530	μV	
<b>Output REL</b>						
Output Low Current	I <sub>OL</sub>	10			mA	V <sub>OL</sub> <1V
Output High Current	I <sub>OH</sub>			-10	mA	V <sub>OL</sub> >(V <sub>DD</sub> -1V)
Output Low current Lock time	T <sub>OL</sub>		2.3		s	Non-adjustable
Output High current Lock time	T <sub>OH</sub>	2.3		4793	s	
<b>Input SENS/ONTIME</b>						
Voltage Input Range		0		V <sub>DD</sub>	V	0V to ¼ V <sub>DD</sub>
Input Bias Current		-1		1	μA	
<b>OEN</b>						
Input Low Voltage	V <sub>IL</sub>			0.2V <sub>dd</sub>	V	OEN Threshold Value From High Voltage to Low Voltage
Input High Voltage	V <sub>IH</sub>	0.4V <sub>dd</sub>			V	OEN Threshold Value From High Voltage to Low Voltage
Input Current	I <sub>I</sub>	-1		1	μA	V <sub>SS</sub> <V <sub>IN</sub> <V <sub>DD</sub>
<b>Oscillator &amp; Filter</b>						
Low pass filter cut-off frequency				7	Hz	
High pass filter cut-off frequency				0.44	Hz	
Oscillator frequency on Chip	F <sub>CLK</sub>			64	kHz	

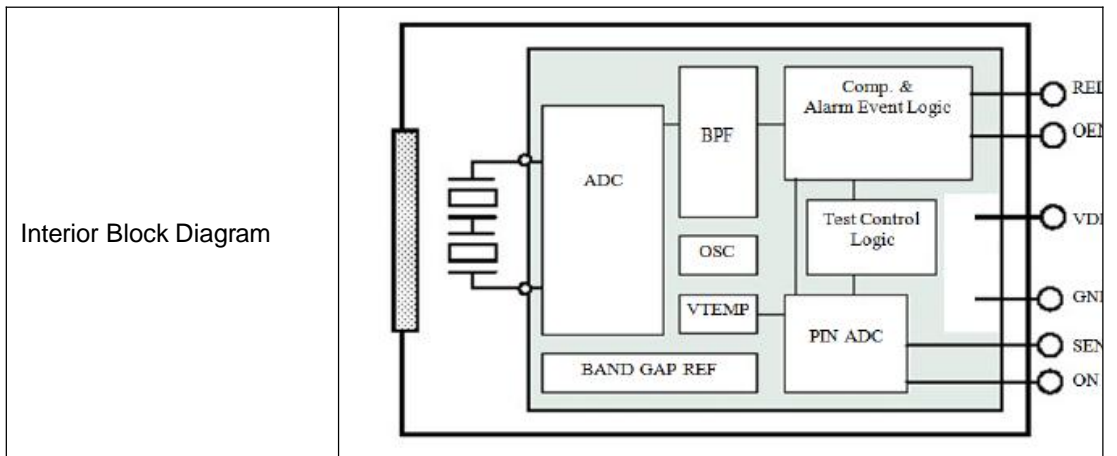

## n Adjustable Relay Time

Step	ONTIME Central Voltage (V)	ONTIME(s)	Voltage(V)	Resistor Value for ONTIME PIN ( $\pm 1\%$ )	
	$(V_{DD} * (\text{Step} * 2 + 3)) / 128$	Typical	(VDD=3V)	Pull-Up Resistor	Pull-Down Resistor
0	3/128 or Lower	2.3	0	Non	0R
1	$(V_{DD} * 2 + 3) / 128$	4.7	0.07	1M	24K
2	$(V_{DD} * 4 + 3) / 128$	7	0.117	1M	39K
3	$(V_{DD} * 6 + 3) / 128$	9.4	0.164	1M	56K
4	$(V_{DD} * 8 + 3) / 128$	18.7	0.21	1M	75K
5	$(V_{DD} * 10 + 3) / 128$	37	0.257	1M	91K
6	$(V_{DD} * 12 + 3) / 128$	56	0.304	1M	110K
7	$(V_{DD} * 14 + 3) / 128$	1min 15 sec	0.351	1M	130K
8	$(V_{DD} * 16 + 3) / 128$	2min 30 sec	0.398	1M	150K
9	$(V_{DD} * 18 + 3) / 128$	5min	0.445	1M	174K
10	$(V_{DD} * 20 + 3) / 128$	7min 29 sec	0.492	1M	200K
11	$(V_{DD} * 22 + 3) / 128$	9min 59 sec	0.539	1M	220K
12	$(V_{DD} * 24 + 3) / 128$	19min 58 sec	0.585	1M	240K
13	$(V_{DD} * 26 + 3) / 128$	39min 56sec	0.632	1M	270K
14	$(V_{DD} * 28 + 3) / 128$	59min 25 sec	0.679	1M	294K
15	$(V_{DD} * 30 + 3) / 128$ or Higher	1hour 20min	3	0R	Non

## n Adjustable Sensitivity

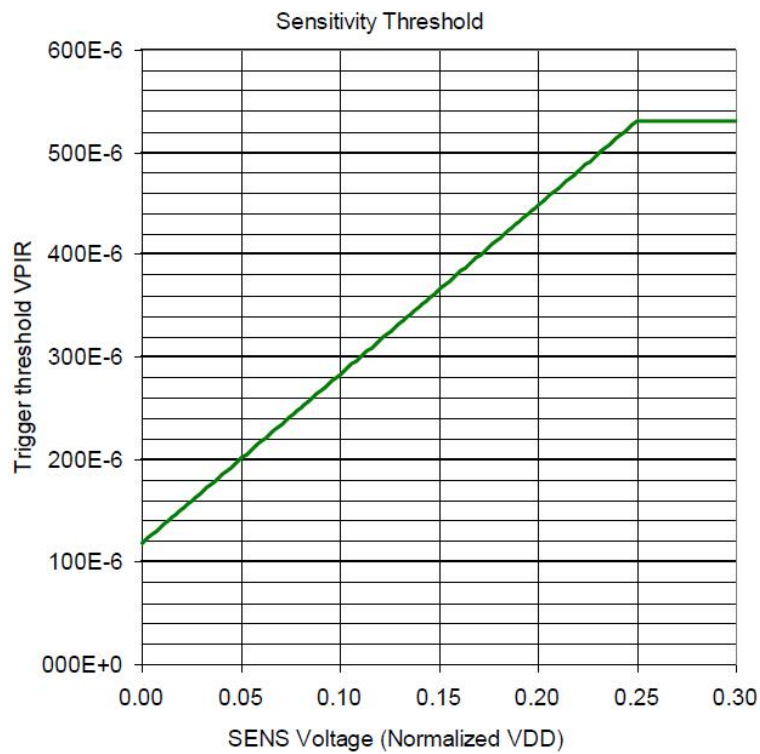

## OEN PIN Hysteresis Level

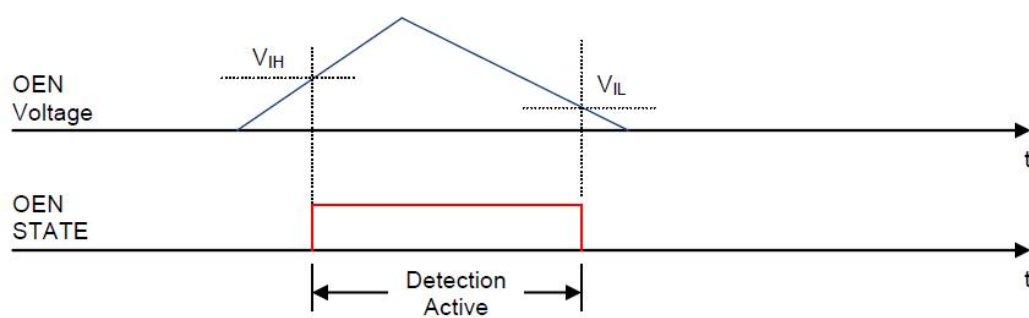

## n Typical Application

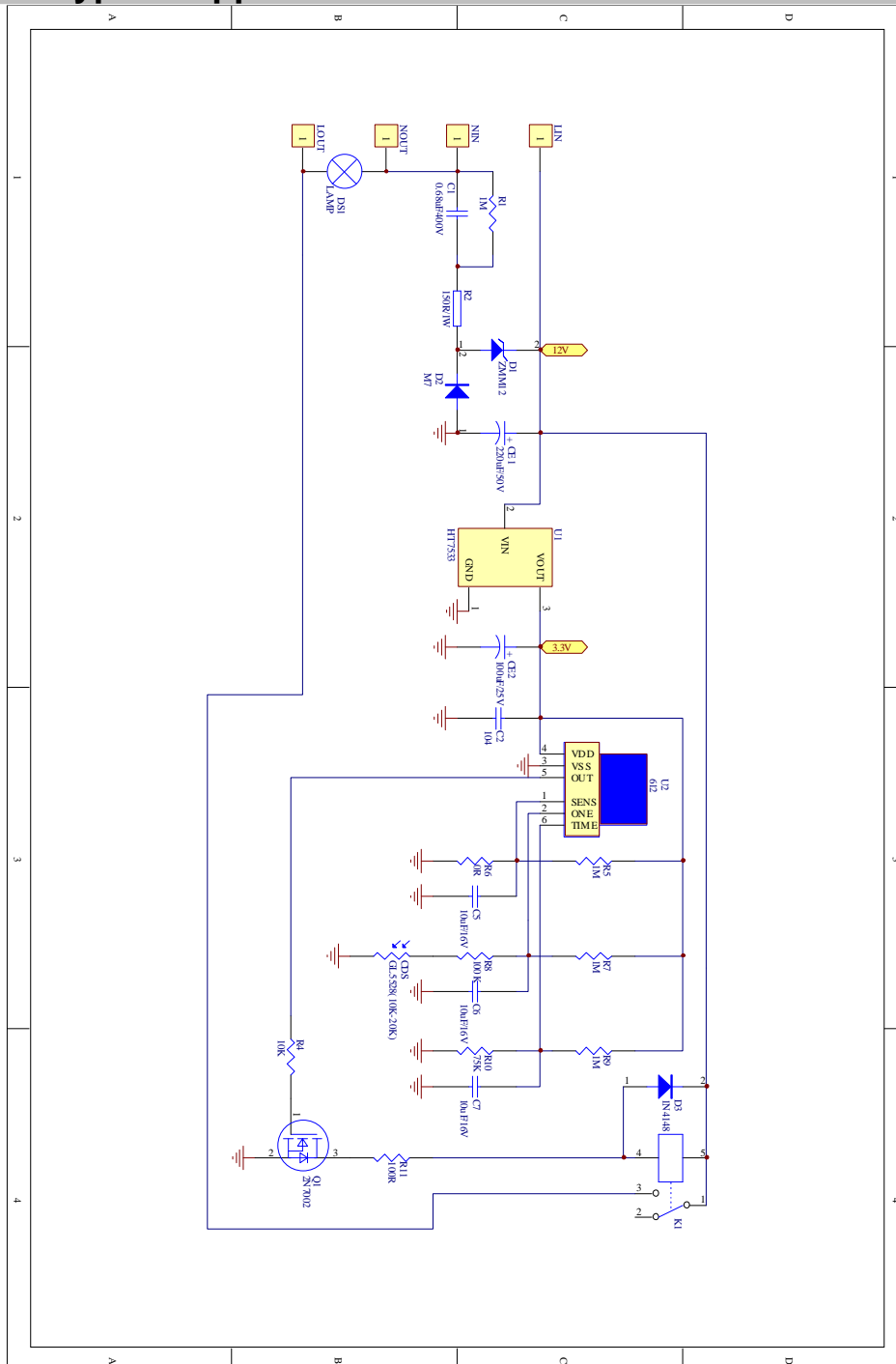

Notes: This is only for reference circuit of Am612 PIR Sensor for simple intrusion detector for wired alarm systems.

## n Spectral Response of Window Materials

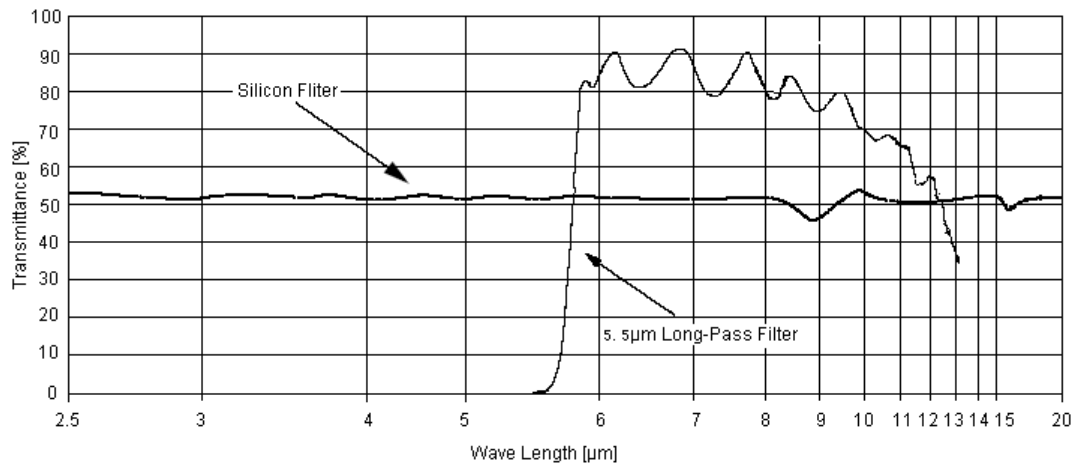

### Notice:

The typical average transmissivity curve of 5.5 μm pass IR filter is figured, which is vacuumed on silicon filter.

## n View of Field



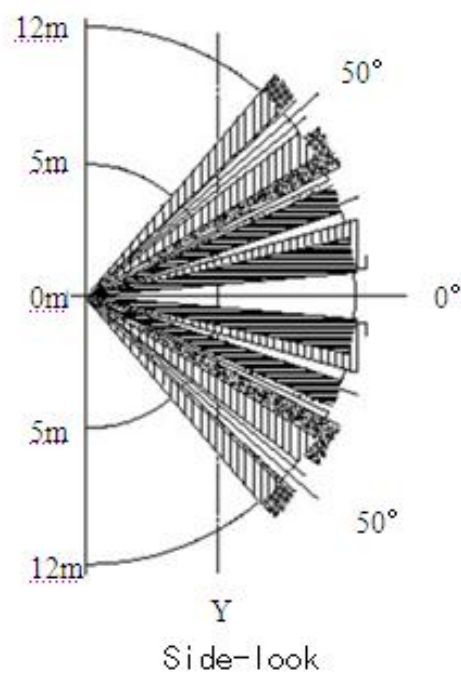
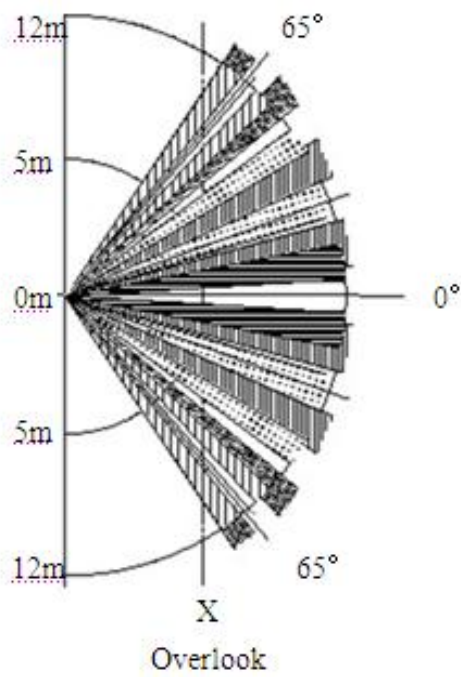

X-Y sectional view

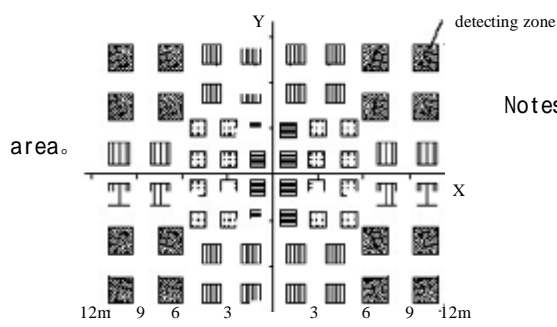

- Notes:
- 1.X-Y sectional view represent the detecting area.
  - 2.Objects with temperature difference can be Detected in the vertical level.

## n Fresnel Lens for Human Body Detection

